

Hydraulic Actuator Valve Linkage Kit for VB-7XXX Series Valves General Instructions

Application

The AV-7600-1 valve linkage kit is used to field assemble MA-521X, MF-5X13, MP-521X, MP-541X, MP-551X, MPR-561X, and MPR-571X round hydraulic actuators to 1/2" through 2" VB-7XXX series valve bodies only.

Features

- Provides direct couple interface between MA, MF, MP, and MPR-5XXX actuators and valve bodies.
- Kit fits all VB-7XXX series valve bodies.
- Optimized linkage springs for maximum close off.

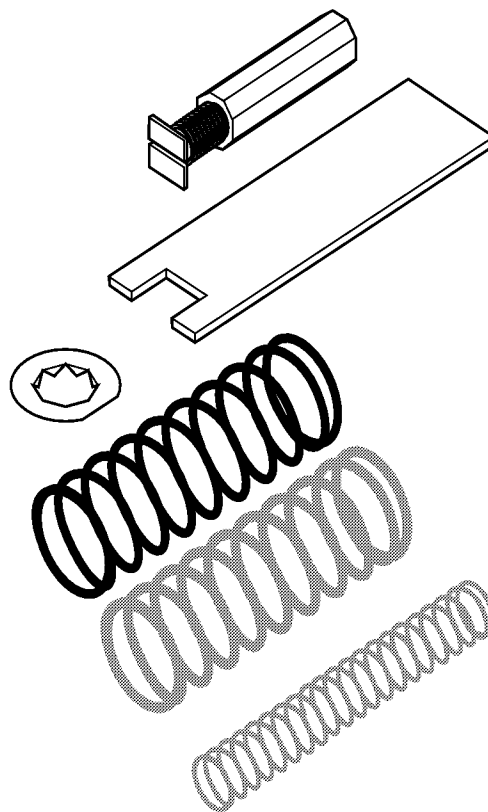

Spring Selection and Calibration

The springs in the AV-7600-1 kit are used with selected actuators for specific valves and/or valve sizes. Reference Table-1.

Table-1 Spring Usage for VB-7XXX Valves.

Valve	Size	Spring(s)	MP-521X Series ^a	
			Controller Calibration ^b	Nominal Control Range ^b
VB-721X VB-725X	1/2" to 1-1/4" (15 to 32 mm)	Large Unpainted	7.5 Volts	6 to 9 Volts
			15 mA	12 to 18 mA
VB-727X Normally Open	1/2" thru 2" (15 to 50 mm)	Black ^c (highest close off)	5.0 Volts	3.5 to 6.5 Volts
			10 mA	7 to 13 mA
VB-731X - Mixing VB-732x - Diverting VB-7332 - Sequencing	1/2" thru 2" (15 to 50 mm)	Large Unpainted PNV-145-48 ^d Blue with small unpainted booster ^e	7.5 Volts	6 to 9 Volts
			7.5 Volts	7 to 8 Volts
			15 mA	14 to 16 mA
VB-722X, VB-726x & VB-728x Normally Closed	1/2" thru 1-1/4" (15 to 32 mm)	Large Unpainted ^f	7.5 Volts	6 to 9 Volts
			15 mA	12 to 18 mA
	1/2" thru 2" (15 to 50 mm)	Large and small unpainted booster (highest close off)	7.5 Volts	6 to 9 Volts
			15 mA	12 to 18 mA

^a MA, MF, MP-541X, and MP-55XX actuator positioning is independent of spring selected.
^b When using a System 8000 controller or a 4 to 20 mA signal across a 500 Ohm resistor to get the proper voltage.
^c The black spring used on a normally open valves may eliminate the need for positive positioning actuators.
^d PNV-145-48 Blue spring is not part of this kit. It is only required for controllers limited to 10 volts or 20 mA maximums.
^e Used with signals limited to 10V such as 0 to 10 Vdc and 4 to 20 mA across a 500 Ohm resistor. Note a reduced control range.
^f The small unpainted spring may be added to provide addition close off.

Applicable Literature

F-Number	Description	Audience	Purpose
F-23638	Siebe Cross-Reference Guide	<ul style="list-style-type: none"> - Sales Personnel - Application Engineers - Installers - Service Personnel 	Provides specifications and part number cross referencing of phased out controls with the new Invensys Building Systems controls.
F-26789	Invensys Component Cross-Reference Guide	<ul style="list-style-type: none"> - Sales Personnel - Application Engineers - Installers - Service Personnel 	
F-21683	Siebe Reference Manual	<ul style="list-style-type: none"> - Sales Personnel - Application Engineers - Installers - Service Personnel 	Provides a collection of general and installation instructions and other reference documents
F-25683	Invensys Controls Catalog	<ul style="list-style-type: none"> - Sales Personnel - Application Engineers - Installers - Service Personnel 	Provides descriptions and specifications for the Invensys Building Systems components.
F-26080	EN-205 Water System Guidelines	<ul style="list-style-type: none"> - Application Engineers - Installers - Service Personnel - Start-up Technicians 	Describes Invensys Buildings Systems approved water treatment practices.
F-26280	AV-601 Linkage Extension Kit General Instructions	<ul style="list-style-type: none"> - Application Engineers - Installers - Service Personnel - Start-up Technicians 	Describes the linkage extension kit's features, specifications and possible applications. Provides step-by-step installation instructions.

SPECIFICATIONS

Temperature Restrictions

Verify that temperature of the media in the valve versus the ambient temperature at the actuator does not exceed the ratings shown in Table-2.

Table-2 Restrictions on the Maximum Ambient Temperature for the Valve Actuator.

Max. Temperature of Media in °F (°C) in the Valve Body (Check Ratings of the Valve)	Max. Ambient Temperature in °F (°C) of MF-5X1X, MP-541X, or MP-551X		Max. Ambient Temperature in °F (°C) of MA-521X or MP-521X	
	AV-7600-1 Only for Chilled Water Applications Only	AV-7600-1 & AV-601	AV-7600-1 Only	AV-7600-1 & AV-601
366 (180)	Do Not Use	88 (31)	90 (32)	90 (32)
340 (171)	Do Not Use	93 (34)	100 (38)	100 (38)
281 (138)	Do Not Use	103 (39)	115 (46)	140 (60) ^a
181 (83)	Do Not Use	120 (48)	140 (60) ^a	140 (60) ^a
80 (26)	140 (60) ^a	140 (60) ^a	140 (60) ^a	140 (60) ^a

^a Maximum allowable ambient temperature of the actuator.

The AV-601 linkage extension provides thermal insulation between the valve and actuator. It is required for all heating valves with MF-5X13, MP-541X, MP-551X, MPR-561X, MPR-571X, and MPR-581X actuators. It is recommended for cooling valves with MF-5X13, MP-541X, MP-551X, MPR-561X, MPR-571X, and MPR-581X actuators. It is also used for higher ambient and fluid temperatures with MA-521X and MP-521X actuators. Refer to **AV-601 Linkage Extension Kit General Instructions, F-26280** for installation procedures.

Table-3 Nominal Hydraulic Two-Way Valve Close Off Ratings. (See Table-1 for controller calibration.)

Valve Size	Spring Closes (Normally Closed)				Spring Opens (Normally Open)	
	MP-5X1X Analog Actuators: 6 to 9, 0 to 10 Volt, and 4 to 20mA		MA-521X & MF-521X Digital Actuators: 2 Position and Floating		All Actuators: Analog, 2 Position, and Floating	
	Close Off Rating with Springs Shown Psi (kPa)					
	Unpainted	Unpainted with Booster	Unpainted	Unpainted with Booster	Unpainted	Black
1/2 inch (15mm)	130 ^a (900)	250 (1700)	200 (1300)	250 (1700)	130 (910)	250 (1700)
3/4 inch (20 mm)	80 (550)	180 (1200)	130 (910)	200 (1300)	80 (550)	200 (1300)
1 inch (25 mm)	40 (270)	60 (410)	50 (340)	90 (620)	40 (270)	150 (1000)
1-1/4 inch (32 mm)	25 (170)	40 (270)	35 (240)	60 (410)	25 (170)	90 (620)
1-1/2 inch (40 mm)	15 (100)	25 (170)	20 (140)	35 (240)	15 (100)	60 (410)
2 inch (50 mm)	6 (40)	14 (95)	10 (70)	20 (140)	6 (40)	35 (340)

^a Shaded area as shipped from factory.

Note: Close off ratings describe only the differential pressure which the actuator can close off with adequate seating force. Consult valve body specifications for limitations.

Table-4 Nominal Hydraulic Three-Way Valve Close Off Ratings. (See Table-1 for controller calibration.)

Valve Size	Close Off Rating Psi (kPa) ^a Differential pressure between A & B ports					
	Spring Closes "A" Port				Actuator Closes "B" Port	
	MX-521X Analog Actuators: 6 to 9 and 0 to 10 Volt, 4 to 20 mA ^b		MA-521X & MF-521X Digital Actuators: 2 Position and Floating		All Actuators: Analog, 2 Position, and Floating	
	VB-731X Mixing	VB-732X Diverting	VB-731X Mixing	VB-732X Diverting	VB-731X Mixing	VB-732X Diverting
1/2 inch (15mm)	130 (900)	250 (1700)	200 (1300)	250 (1700)	130 (910)	250 (1700)
3/4 inch (20 mm)	80 (550)	250 (1700)	130 (910)	250 (1700)	80 (550)	250 (1700)
1inch (25 mm)	40 (270)	250 (1700)	50 (340)	250 (1700)	40 (270)	250 (1700)
1-1/4 inch (32 mm)	25 (170)	250 (1700)	35 (240)	250 (1700)	25 (170)	250 (1700)
1-1/2 inch (40 mm)	15 (100)	250 (1700)	20 (140)	250 (1700)	15 (100)	250 (1700)
2 inch (50 mm)	10 (70)	250 (1700)	14 (95)	250 (1700)	10 (70)	250 (1700)

^a VB-7332, 1/2 inch sequencing valves close off 35 Psi (240 kPa) on both ports.

^b Factory shipments have unpainted large springs. For 0 to 10 Volt and 4 to 20 mA controllers use blue and booster springs. (See Table-1.)

Note: Close off ratings describe only the differential pressure which the actuator can close off with adequate seating force. Consult valve body specifications for limitations.

INSTALLATION

Inspection

Inspect the package for damage. If damaged, notify the appropriate carrier immediately. If undamaged, open the package and inspect the device for obvious damage. Return any damaged products.

Requirements

- Tools:
 - Screwdriver appropriate for slotted spring compression screw (not provided)
 - Linkage wrench (provided) or TOOL-20-1, packing and linkage wrench (not provided)
- Installer must be a qualified, experienced technician

Caution:

- Avoid locations where excessive moisture, corrosive fumes, or vibration is present.
- Install all two-way valves so that they close against the flow. An arrow on the valve body or a tag indicates the proper flow direction.
- Always install three-way mixing valves with two inlets and one outlet.
- The actuator must be above the center line of the valve. For steam applications mount the actuators above the valve body at 45° from vertical.

Linkage Kit Installation

The AV-7600-1 linkage kit used on VB-7XXX series valve bodies requires no stem height setting.

Procedure

The linkage kit is assembled onto the VB-7XXX valve body with the stem in the up position.

1. Select the appropriate spring(s) as detailed in Figure-1.
2. Thread the hexagon coupler onto the valve stem all the way to the bottom of the stem thread, finger-tight (Figure-1). Pull the valve stem completely up.

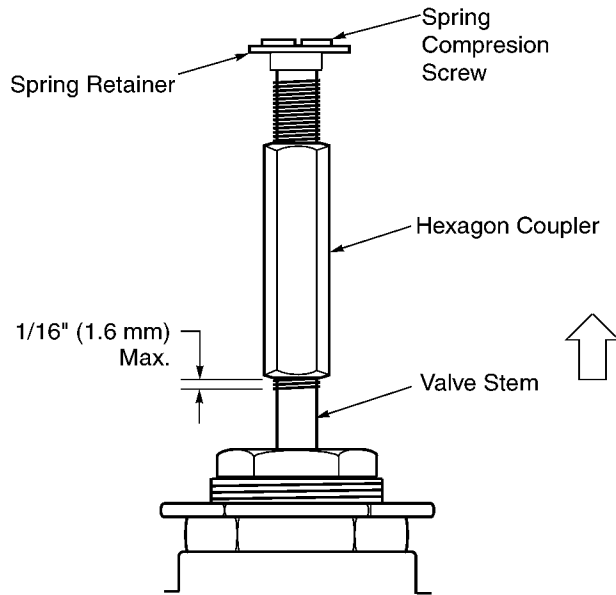

Figure-1 Installation of Hexagon Coupler and Spring Compression Screw.

Caution: The hexagon coupler must reach to within 1/16" (1.6 mm) of the smooth section of the stem to assure proper seating. Do not use the Spring Compression Screw to run the Hexagon Coupler down.

3. On normally closed valves (1-1/2" [40 mm] to 2" [50 mm] mandatory) slip the small unpainted booster spring over the stem.
4. Start the spring(s) compression screw one turn or more into the hexagon coupler.
5. Slip the spring over the coupler and the spring compression screw.
6. Place the retainer over the screw. Twist the retainer 45° to lock it in place.
7. Insert the linkage wrench (supplied with kit, also included on TOOL-20-1) through the spring coils about 3 coils from the bottom to hold hexagon coupler.
8. Hold the wrench from turning and tighten the spring compression screw. To establish proper linkage height, run the spring compression screw down until the screw end bottoms firmly on the stem top (Figure-2).

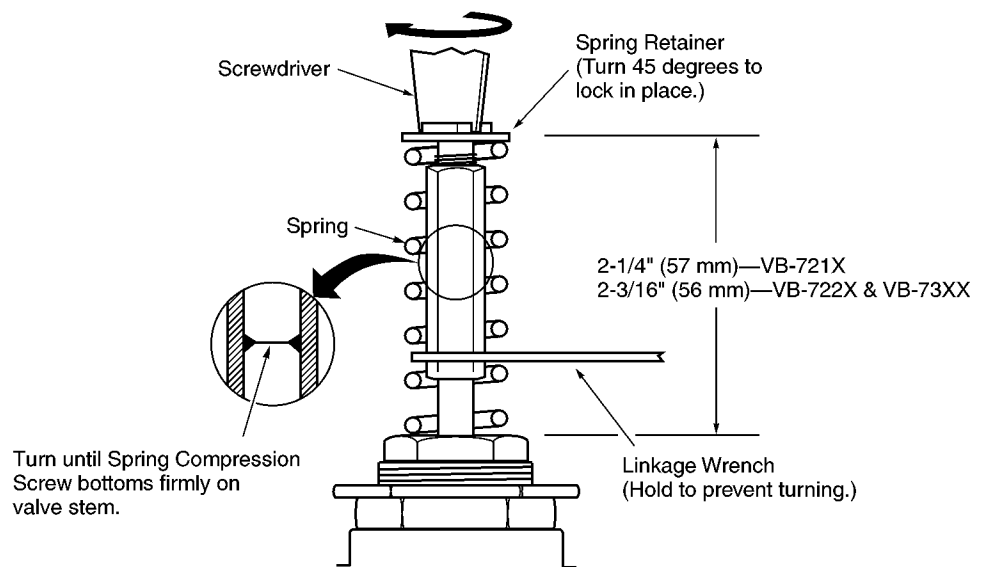

Figure-2 Completing Linkage Kit Assembly to Valve.

9. Confirm the stem height setting (Figure-2):
 - 2-5/16" (59 mm) maximum after installation on stem up open valves (VB-721X).
 - 2-7/32" (56 mm) maximum on stem up closed valves (VB-722X) or three-way valves (VB-73XX).
10. Center the spring on top and bottom to assure smooth actuator operation. See Figure-3 for total assembly components required.

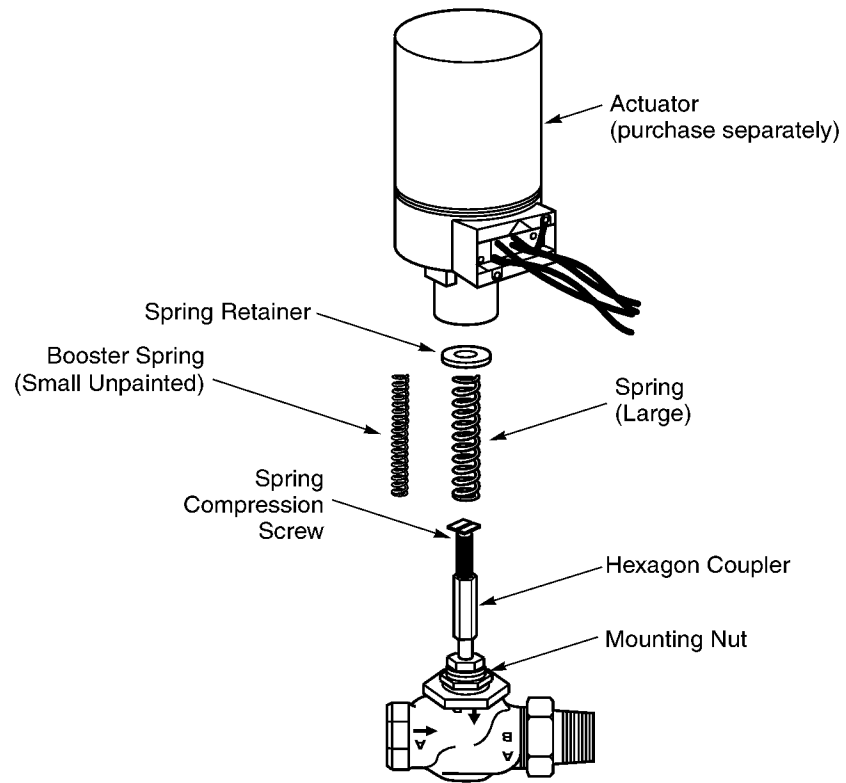

Figure-3 Assembly of Linkage Kit onto VB-7XXX Series Valve.

MAINTENANCE

The actuator linkage requires no maintenance.

For linkage removal, insert wrench through springs and hold. Remove spring compression screw and parts.

Regular maintenance of the total system is recommended to assure sustained, optimum performance. Hard water leaves abrasive deposits and reduces component life. To maximize valve life, consult **EN-205 Water System Guidelines, F-26080**.

FIELD REPAIR

Individual parts of the actuator linkage are not repairable. Replace an inoperative actuator linkage with a functional unit or replace individual parts as necessary (Table-5 and Figure-4).

Table-5 AV-7600-1 Replacement Parts.

Item (See Figure-4)	Part No.	Description
1	P4-14	Large Unpainted Spring
2	P4-14-10-1	Small Unpainted Booster Spring
3	PNV-145-45	Large Black Spring
4	YBA-559	Spring Retainer
5	NYBA-80	Stem Coupler (hexagon)
	NYBA-79	Spring Compression Screw
6	NYBA-82	Linkage Wrench

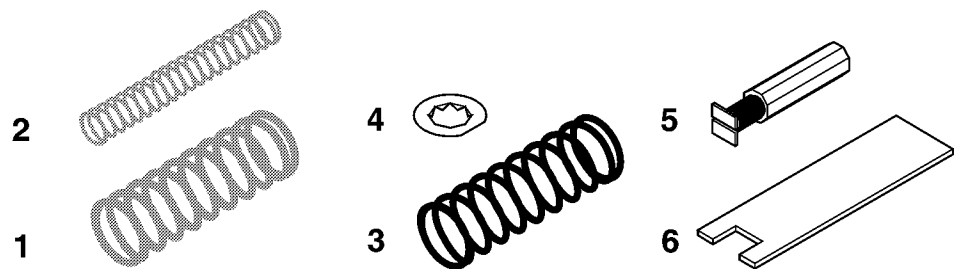

Figure-4 AV-7600-1 Hydraulic Actuator Valve Linkage Kit.

